

# The Green Products Company

*"Building A Greener Tomorrow!"*

A DIVISION OF ACOUSTICAL SURFACES, INC.

123 Columbia Court North ■ Suite 201 ■ Chaska, MN 55318  
 (952) 448-5300 ■ Fax (952) 448-2613 ■ (800) 708-0517

Email: sales@thegreenproductscompany.com  
 Visit our Website: www.thegreenproductscompany.com

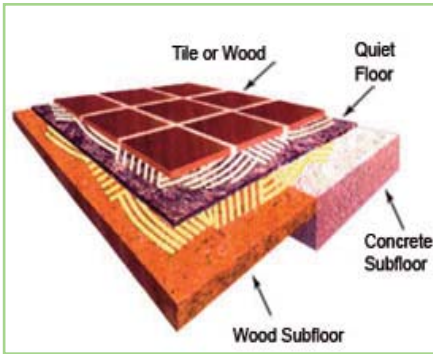

## QUIET FLOOR

### GREEN QUALITIES:

- Certified 100% Pre-consumer recycled synthetic fiber
- Warranted for 15 years – extended Life Cycle
- Antimicrobial additive inhibits mold growth
- Can be glued directly over old vinyl composite tile or no cushioned sheet vinyl – avoids the potential exposure to asbestos
- Antimicrobial additive inhibits mold growth

### CERTIFICATIONS/ PERFORMANCE RATING

- SCS Certified Advantage Gold
- SCS Certified Recycled Content

### DESCRIPTION:

**Material:** Certified 100% Pre-consumer recycled synthetic fiber.

**Features:** Lightweight – smooths minor floor imperfections.

### PRODUCT DATA:

**Thickness:** 1/8" **SIZES:** 3' x 33 1/3' & 61" x 60' rolls.

**Sizes:** 2' x 4' or 4' x 8' panels.

**Weight:** 2.22 oz/sq. ft.

**Density:** 13.3 #/cub. ft.

### FLAMMABILITY:

Meets Federal Flammability Standard (PSC-FFI-70 (Pill Test)).

### APPLICATIONS:

Flooring underlay to reduce impact floor noise in commercial and residential construction.

### INSTALLATION:

Noise S.T.O.P.™ Acoustical Adhesive.

STC per ASTM E-90-97 (Airborne)						
125Hz	250Hz	500Hz	1KHz	2KHz	4KHz	STC
35	40	54	63	70	71	52

IIC per ASTM E-492-92 (Impact)						
125Hz	250Hz	500Hz	1KHz	2KHz	4KHz	IIC
58	56	44	30	20	18	58

Continued on next page...



# The Green Products Company

*"Building A Greener Tomorrow!"*

A DIVISION OF ACOUSTICAL SURFACES, INC.

123 Columbia Court North ■ Suite 201 ■ Chaska, MN 55318  
 (952) 448-5300 ■ Fax (952) 448-2613 ■ (800) 708-0517

Email: [sales@thegreenproductscompany.com](mailto:sales@thegreenproductscompany.com)

Visit our Website: [www.thegreenproductscompany.com](http://www.thegreenproductscompany.com)

## INSTALLATION CONT:



**FIIC 60**

**FIIC 39** 20" Pocolain Tile

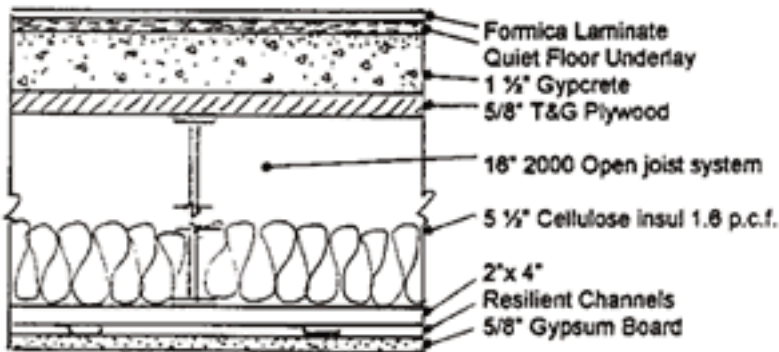

**STC 52**

**STC 53**  
**IIC 52** 12" X 12" Ceramic Glazed Tile

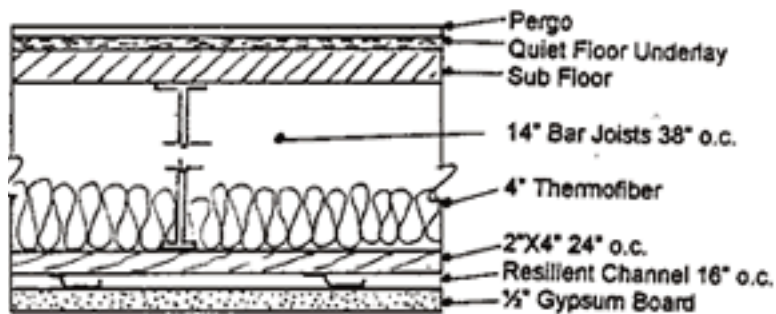

**IIC 58**